

Document Number:
Issue:

ALWSR+
005

ALWSR

**High Performance Audio Voltage
Regulator**

**Assembly, Test and Application
Manual**

Copy Number: _____

ALWSR High Performance Audio Voltage Regulator

Prepared By: Andrew L. Weekes

Date: 19 July 2002

This document together with all the information disclosed therein is the exclusive property of ALW Audio. This document shall not be copied or distributed to third parties in the U.K. or overseas or altered, copied or reproduced in whole or in part except by express written authorisation of ALW Audio.

Commercial in Confidence

Document Number: ALWSR Rev 2.9	Issue Number: 005	Page i
-----------------------------------	-------------------	--------

filename: ALWSR rev2.9 rev005.doc

21/03/2004

Table of Contents

1	Modification/Amendment Record + Errata	ii
2	List of Abbreviations	v
3	Warnings and Cautions	vi
1	INTRODUCTION	1
2	Circuit Description	2
3	EQUIPMENT REQUIRED	4
4	PREPARATION	5
5	ASSEMBLY	6
6	OUTPUT VOLTAGE	7
7	Super Regulator Operating Conditions	8
7.1	Super Regulator + Tracking Pre-Regulator Operating Conditions.....	8
8	TESTING	9
8.1	Tracking Pre-Regulator.....	9
8.2	Super Regulator	10
9	APPLICATION	11
9.1	Choosing configuration.....	11
9.2	Choosing voltage	11
9.3	Connecting.....	11
9.4	Performance Verification.....	11
10	MAINTENANCE & REPAIR	12
10.1	Health and Safety.....	12
11	CALIBRATION	13
12	The ‘0.9’ BTS modifications.	14
13	Annex A – Parts List, Schematics, Component Overlays + Component ID	15
13.1	Component Identification.	16
13.2	ALWSR+ Schematic (not 5V version).....	17
13.3	ALWSR+ Component Overlay (Not 5V version)	18
13.4	ALWSR+ Schematic (5V version)	19
13.5	ALWSR+ Component Overlay (5V Version)	20
13.6	ALWSR- Schematic	21
13.7	ALWSR- Component Overlay.....	22
14	Annex B – Regulator Output Voltage	23
15	Annex C – Wiring / Connection Schemes.	24

Commercial in Confidence

Document Number: ALWSR Rev 2.9	Issue Number: 005	Page iii
-----------------------------------	-------------------	----------

filename: ALWSR rev2.9 rev005.doc

21/03/2004

Table of Annexes

13 Annex A – Parts List, Schematics, Component Overlays + Component ID. 15
14 Annex B – Regulator Output Voltage..... 23
15 Annex C – Wiring / Connection Schemes..... 24

Table of Figures

Figure 1 - Pre-regulator Test Connections..... 9
Figure 2 - Super Regulator Test Connections..... 10
Figure 3 - Optimal Star Wiring..... 24
Figure 4 – Bad Wiring..... 24
Figure 5 - Super Regulator only, local sense 25
Figure 6 - Super Regulator only, Remote Sense 25
Figure 7 - Super Regulator + Tracking Pre-regulator, local sense 26
Figure 8 - Super Regulator + Tracking Pre-regulator, remote sense 26
Figure 9 - Sense loop filter 27

Commercial in Confidence

Document Number: ALWSR Rev 2.9	Issue Number: 005	Page iv
-----------------------------------	-------------------	---------

2 List of Abbreviations

AC	Alternating Current
DC	Direct Current
mA	Milliamp
mm	Millimetre
ms	Millisecond
PCB	Printed Circuit Board
RF	Radio Frequency
UHF	Ultra High Frequency
V	Volt
W	Watt

Commercial in Confidence

Document Number: ALWSR Rev 2.9	Issue Number: 005	Page v
-----------------------------------	-------------------	--------

filename: ALWSR rev2.9 rev005.doc

21/03/2004

3 Warnings and Cautions

Failure to follow the instructions contained in this manual could result in damage to equipment and may cause injury to personnel.

Whilst every attempt has been made to offer practical advice and highlight safety issues, the practice of modifying equipment from the manufacturers original specifications raises safety issues if the operator is not competent to perform the basic tasks required.

As a minimum some basic electrical knowledge and the ability to solder cleanly and reliably are a necessity. The super-regulator design is inherently robust, and features numerous abuse protection mechanisms, but ultimate responsibility for safe application lies firmly in the hands of the user.

Please check the circuit to be powered has had any large (>1000uF) smoothing caps removed before modifying with these regulators. Connecting such a large capacitor to the regulator output may at best produce instability, at worst may cause the device to fail.

The components used within the regulator have been carefully selected for best price / performance ratio, and so when considering ‘tweaking’ the basic circuit bear in mind this circuit is highly developed, and the result of some 5 man-years combined work.

The author is always willing to offer advice, and genuinely interested and open-minded with regard to user modifications, and customer feedback. Please feel free to contact me, via email, on alweekes@beeb.net.

Refer also to Section 10.1 regarding Health and Safety warnings.

Commercial in Confidence

Document Number: ALWSR Rev 2.9	Issue Number: 005	Page vi
-----------------------------------	-------------------	---------

filename: ALWSR rev2.9 rev005.doc

21/03/2004

1 INTRODUCTION

This manual covers the assembly, testing and application of the ALW Audio Super Regulators for audio applications.

The author has found that every audio circuit is sensitive to the quality of the power supply that feeds it. The power supply rails of an audio circuit are another input to that circuit, and it is desirable to minimise and noise present on these rails, since a proportion of this noise appears at the output of the circuitry, masking musical information.

Some of the benefits afforded by these regulators are listed below: -

1. **Ultra Low Noise.**

The noise output of these regulators requires specialist test equipment in order to be able to measure it. A very low noise amplifier, with very high gain is necessary to raise the noise above the noise floor of most measuring equipment. Low noise provides benefits in terms of low-level detail resolution when used on analogue supplies. It is also used to reduce jitter dramatically in digital systems, such as CD players.

2. **Ultra Low Output Impedance.**

The ability of the regulators to keep their output constant and unvarying with load changes is very important. Normally an increase in current demand, or noise injected into the regulator o/p from the circuitry being powered, results in significant dynamic noise present at the regulator o/p. The load regulation and output impedance of these regulators is exceptional. In almost all cases the wiring from the regulator will have higher impedance and resistance. This performance advantage is maintained across a dramatically wider bandwidth than any standard regulator circuit and the sonic gains from this factor alone are dramatic. It also brings cost benefits in that more circuitry can be powered from just a single regulator, since there is much less interaction between circuit, providing wiring is connected correctly, see Figure 3 and Figure 4 for more information.

3. **Very High Line Rejection.**

The ability of a regulator to attenuate noise present on its input (and hence isolate the circuitry being powered from such artefacts) is an important performance parameter. Most standard regulators offer, at best, 80dB of line rejection, but this degrades rapidly with increasing frequency. Specialist high-resolution test equipment is necessary to measure this parameter of the super-regulators, but it is at least 130dB at low frequencies, and maintains this advantage over a large bandwidth.

4. **Tracking Pre-Regulator**

The addition of a tracking pre-regulator brings further performance enhancements, and adds all of the safety features and benefits of it's internal protection circuitry to the super-regulator. The unit as a whole is then well protected against short-circuits, thermal overload and device failure from abuse, making it safe and reliable to apply to the users expensive equipment.

Commercial in Confidence

Document Number: ALWSR Rev 2.9	Issue Number: 005	Page 1
-----------------------------------	-------------------	--------

21/03/2004

2 Circuit Description

The ALWSR high performance audio regulator is a highly developed linear voltage regulator, based very closely on the design developed by Walter Jung, a keen audiophile and now retired senior engineer at Analog Devices. The early implementations that appeared in 'The Audio Amateur' were ably assisted by Jan Didden and Gary Galo. The author is indebted to the above for sharing the work that went into these regulators, and subsequent developments.

The circuit function is based on a classic op-amp based linear regulator, with a number of significant performance enhancements.

The circuit starts with a precision low noise reference (ZD1). This is most commonly a 6.95V LM329 sub-surface Zener, but can be other devices, depending upon desired output voltage / noise performance. This Zener is biased through a resistor (R5), from the regulator +ve sense point, which is the quietest +ve rail of the system and biasing the device in this manner means that the reference is well isolated from the effects of noise at the regulator input.

The output of the reference is then filtered, via a simple RC network (R7 / C4). The resistor values are chosen so that the error amplifier (IC2 or IC3) inputs see a low, and matched source impedance of 500 Ohms, thereby facilitating optimum DC stability and dynamic performance and minimising EMC susceptibility. C4 is a very high performance, low ESR device in order to maximise the filtering effect from the low impedances used.

D3 and D4 provide protection against excess differential mode voltage at the opamp inputs. They are not strictly necessary for the AD797 opamp, and can be left out for some very minor performance improvement, since the AD797 incorporates these diodes internally. This is not be the case for many other op-amps though.

It is the opinion of the author that it is best to leave the diodes in place under all circumstances. The performance degradation is slight, and the author would rather a very cheap external component fail, as opposed to degrading or destroying an expensive IC!

The reference voltage at the input of the op-amp is compared to a proportion of the output voltage, via the +VSENSE and 0VSENSE inputs and a potential divider (R8 / R9). +VSENSE / 0VSENSE can be connected directly to the relevant regulator outputs, or to the load (Remote Sensing), thereby improving performance by ensuring the regulator performance is not degraded by the interconnecting wiring's finite impedance. The ratio of these two resistors sets the output voltage, and the combined parallel impedance of these two values should be 500 Ohms, for optimum dynamic and DC stability. To prevent noise being amplified by the gain of the error amplifier, the gain is reduced to unity at high frequencies, by the addition of a bypass capacitor (C7). This is matched in value and type to C4, in order to equalize AC impedances at the error amp inputs, thereby improving dynamic performance.

Commercial in Confidence

Document Number: ALWSR Rev 2.9	Issue Number: 005	Page 2
-----------------------------------	-------------------	--------

21/03/2004

The error amplifier also obtains its power from the regulator output (bootstrapping), this brings major performance improvements, and is a fundamental feature of the design. As the error amplifier PSRR (Power Supply Rejection Ratio) degrades, with increasing frequency, the regulator performance will normally suffer. This connection scheme augments the error amplifier performance dramatically, giving a significant, frequency-dependant, improvement in the regulator performance parameters. In particular line rejection is enhanced significantly.

The output of the regulator is from the series pass device (Q1). This is controlled from an LED-biased current source (T1 / R1 / D1 / R4). At switch on the current source provides current to Q1 base, which turns it on causing the output voltage to rise. This applies power to the error amplifier and reference, which then starts to control the output voltage, by sinking current (via T2 / R6 / D2) away from the base, reaching equilibrium when the correct output voltage is achieved. The level shift Zener diode (D2) is an essential part of the start-up process, ensuring that if the error amp comes on in a low-output condition there is still enough current available at Q1 base to bring the error-amplifier / reference into the linear operating area. It is bypassed by a high performance low ESR capacitor to reduce the dynamic impedance of the device, and further improve dynamic output impedance of the regulator circuit. Input and output decoupling are an essential part of the stability of the regulator (C1 / C5).

C6 **MUST** be left off initially. In rare circumstances when remote sensing is used, the regulator can occasionally oscillate. The latest versions of these regulators have NEVER oscillated, but earlier revisions using the AD797 error amplifier were very prone to instability. A film capacitor (C6) can be used to decouple the loop at very high frequencies, ensuring stability is maintained. If used the +VSENSE input **MUST** be connected to the load via a 10R resistor *at the load end*. Failure to do this will cause the regulator to oscillate due to the excess phase shift introduced by the high Q of the film capacitor (C6). This is discussed further in the applications section of this manual.

Finally a tracking pre-regulator can be used to further improve performance. The regulator (IC1) is set to produce 2.5V via the potential divider connected between the output, adjustment and Kelvin sense points (R2 / R3). A capacitor across R3 further lowers noise, ripple and improves line rejection bringing truly huge musical improvements to the regulator combination*. The Kelvin sense point TRS1 or TRS2 is connected to the regulator output (OP1 or OP2) or the sense point (+VSENSE), the pre-regulator output is then connected to the Super Regulator input (TROUT to SRIN). The raw +ve supply is then fed in on TRIN, the tracking regulator input.

* This addition is part of the '0.9 BTS' mods, and is a retrofit modification to existing regulators – see section 12 for details.

Commercial in Confidence

Document Number: ALWSR Rev 2.9	Issue Number: 005	Page 3
-----------------------------------	-------------------	--------

3 EQUIPMENT REQUIRED

You will need access to the following basic tools: -

- Soldering Iron and electronics-grade solder
- Wire Cutters (snips), for fine electronics work
- Snipe-nosed pliers
- Multimeter (Preferably Digital)

Additionally the following are highly beneficial, but not essential

- Magnifying glass / Eye Loupe
- Oscilloscope
- Bench Power Supply

Commercial in Confidence

Document Number: ALWSR Rev 2.9	Issue Number: 005	Page 4
-----------------------------------	-------------------	--------

21/03/2004

4 PREPARATION

A clean tidy, well-illuminated area is important for the assembly of these regulators. Failure to assemble the units correctly will, at best, result in a non-functioning unit, at worst will damage components, or degrade performance.

A good magnifier is also beneficial as some component markings can be difficult to read with the naked eye.

Unpack all components and ensure that everything correlates with the list in Section 13.

Please read the

Commercial in Confidence

Document Number: ALWSR Rev 2.9	Issue Number: 005	Page 5
-----------------------------------	-------------------	--------

21/03/2004

5 ASSEMBLY

Start by assembling the physically lowest components first, such as the diodes and resistors. Many components are polarity-sensitive and **MUST** be placed in the board in the correct orientation, the component overlay shows this (e.g. LED has a flat denoting orientation).

Note only IC2 **OR** IC3 are fitted, not both. They offer the choice between conventional leaded devices, and surface-mount technology.

The resistor legs have to be bent close to the body, and a finger is the best tool. Use of pliers can stress the component leg, resulting in premature component failure. The legs are kept short as a specific part of the design, since at high frequencies the leads can introduce unwanted performance degradation.

Solder each component, keeping component bodies close to the PCB.

Ensure you are fitting the components to the correct positions, the PCB has plated-through holes for extra reliability, but this makes component removal much more difficult. In extreme cases an intentional connection made between two sides of the PCB can be removed, by careless rework.

The best way to remove an incorrectly fitted component is to snip the leads and then heat and carefully remove each pin individually. Finally remove excess solder with a solder sucker or desolder braid and replacing the device with a new one. This is expensive if the main error amp (IC2 / IC3) is the component to be replaced – you have been warned!

Once assembly is completed PLEASE spend some time checking and inspecting the PCB for the following errors: -

- Incorrect component placement.
- Incorrect component orientation.
- Accidental solder shorts or splashes (hold board up to a bright light and inspect both sides carefully around each component leg).
- ‘Dry’ poorly soldered joints (i.e. dull or grey joints – all solder joints should be shiny).
- Whiskers of material scraped from the leg of a component during insertion into the PCB. These can give rise to short-circuits to the sense plane of the PCB.

A little time spent now, can save a lot of aggravation and expense later. Almost all production faults can be found by inspection before powering the circuit, and risking damage.

Very Important!

The capacitor C6 (0.01uF) should NOT be fitted at this stage. It is an option that can be used to further enhance stability under difficult applications, and is generally not required. See connection schemes for more information.

Commercial in Confidence

Document Number: ALWSR Rev 2.9	Issue Number: 005	Page 6
-----------------------------------	-------------------	--------

6 OUTPUT VOLTAGE

The output voltage is calculated from the following formula: -

$$V_{out} = V_{ref} * (1 + R8/R9).$$

Additionally $R8 // R9$ (the impedance of the two resistors in parallel) should equal 500 Ohms.

To make this easier the following formula has been derived: -

$$R9 = (500 * V_{out}) / (V_{out} - V_{ref})$$

Once the above is calculated, apply the value obtained above to the following formula: -

$$R8 = R9 * ((V_{out} - V_{ref}) / V_{ref})$$

The two values then can be selected from the closest standard value, or made up from parallel / series combinations.

The table in Annex B gives a range of resistor values for R8 and R9, to set different output voltages. The minimum voltage of the regulator depends upon the reference device used (ZD1).

For an LM329, the recommended range is 8V upwards

For a 2.5V reference the recommended range is 3V upwards

Lower voltage references can be used to obtain lower output voltages

Maximum recommended output voltage is 34V, limited by the error amp specifications.

Other considerations are the available 'head' i.e. raw supply voltage that is available. The voltage between the input and the output of the regulator must be greater than the following values, under all conditions (don't forget mains voltages will cause variations in the voltages of raw, unregulated supplies).

Fit the resistors you require for the desired output voltage.

You can check the values you arrive at using the following formulae: -

$$V_{out} = V_{ref} * (1 + (R8 / R9))$$

Check also that $(R9 * R8) / (R9 + R8)$ is approx 500R (+/-10R ideally).

Commercial in Confidence

Document Number: ALWSR Rev 2.9	Issue Number: 005	Page 7
-----------------------------------	-------------------	--------

7 Super Regulator Operating Conditions

Input to Output voltage must be $\geq 2.5V$ under all conditions. So for a 15V supply, for example, there must be a raw supply of at least 17.5V.

7.1 Super Regulator + Tracking Pre-Regulator Operating Conditions

The tracking pre-regulator maintains a 2.5V input – output differential on the super-regulator. This minimises power dissipation and large voltage variations in the Super Regulator, and enhances performance, lowering noise, improving line rejection and leaving the Super Regulator to do fine control.

When using this option the voltage into the pre-regulator must be 5 volts above the super regulator output voltage, under all conditions. Taking an example output voltage of 15V, there must be a raw supply of at least 20V. The data sheet spec for dropout V of the LM317 is 2.5V max, under individual applications this may be reduced.

With individual testing of the circuit, at the desired load current these figures can often be reduced. Individual testing, on a case-by-case basis is the only way to guarantee correct function though. Some LM317 regulators work with just 1.5-2 volts across them, meaning a supply head of 4-4.5 Volts only.

In order to test this place a load on the regulator (or connect your circuit) and slowly raise the input voltage, the point at which there is 2.5V between SRIN and SROUT is the ***absolute minimum operating voltage for that operating current / load.***

The best indication that the circuit is functioning correctly is that the LED in the current source has reached full brightness (it runs at a lower current than normal, so will be dimmer than one might expect).

See **Section 8 - TESTING** for more details.

Commercial in Confidence

Document Number: ALWSR Rev 2.9	Issue Number: 005	Page 8
-----------------------------------	-------------------	--------

21/03/2004

8 TESTING

It will be hard for most home builders to fully test every parameter of these units, but the author can assure the reader that having built significant numbers of these regulators, not one has failed to meet the desired specifications. To that end some simple checks will provide all the confidence one needs.

8.1 Tracking Pre-Regulator

This is electrically isolated from the super-regulator, and can be tested independently. It is connected, if required, at the wiring / installation phase. The following stages will allow you to test correct function.

1. Apply a source of DC power, preferably from a current limited source (e.g. bench PSU). DC input must be greater than 4-5V, less than 36V
2. Connect the -ve (0V) of the PSU to the TRS1 or TRS2 terminal (Tracking Regulator Sense) connections and connect the +ve of the PSU to the TRIN (Tracking Regulator Input) terminal.
3. Connect a Multimeter, set to read 2.5V, between the TRS1/2 terminals and the TROUT (Tracking Regulator Output) pin. +ve is on TROUT, -ve to TRS1/2.
4. Turn on PSU, preferably increasing voltage slowly, to ensure no excess current drain - the meter should read 2.5V. If not then check the soldering around IC1, R2 and R3, and R2 / R3 component values.

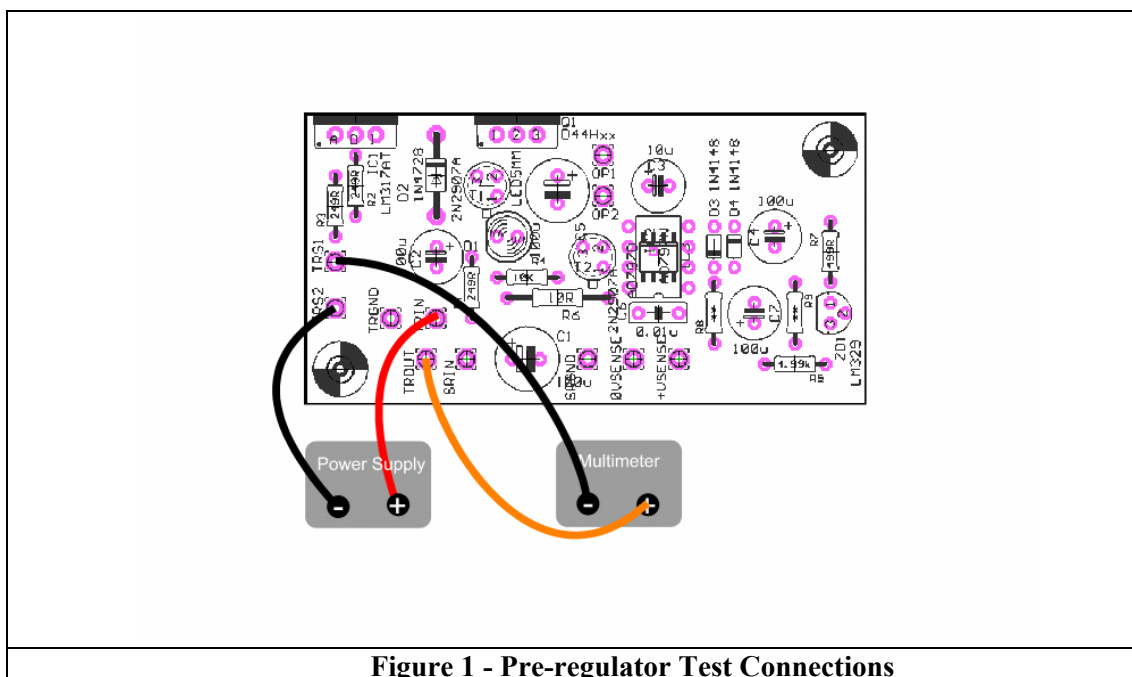

Figure 1 - Pre-regulator Test Connections

Commercial in Confidence

8.2 Super Regulator

This is the most expensive part of the PCB, and is electrically isolated from the pre-regulator for versatility of application. Great care should be taken when making connections and testing this device, since we will initially be doing this without the benefit of the tracking pre-regulator to provide the safety and overload protection features of the design. It is inherently robust, and contains well-specified components of high quality but, like any electronic device, abuse can still damage it. The following procedure will allow you to ensure correct function.

1. Connect +VSENSE to OP1, or OP2 using a SHORT wire link
2. Connect 0VSENSE to SRGND, using a short wire link.
3. Connect a wire to the SRIN terminal of the Super Regulator and a wire to the SRGND terminal. Connect these wires to a bench PSU, or other DC power supply, of less than 35V, connecting SRIN to the +ve, SRGND to the -ve.

Make the above connections with the PSU powered off and ensure the above connections are made correctly – failure to do so WILL damage components permanently.

4. Connect a digital multimeter between SRGND or 0VSENSE and OP1 or OP2, set to a voltage range suitable for the regulator under test.
5. Apply power to the regulator and ensure that the voltage as read by the digital multimeter is correct, and that the LED is illuminated. As an optional step one can examine the regulator output with an oscilloscope, if available, and ensure that the output is a steady DC, with no visible noise or oscillation.
6. Additionally you can test the regulator on a resistive load to ensure that it does not drop under load. As an absolute minimum the regulator can deliver 200mA, most units exceed this specification by a significant amount (500mA+).

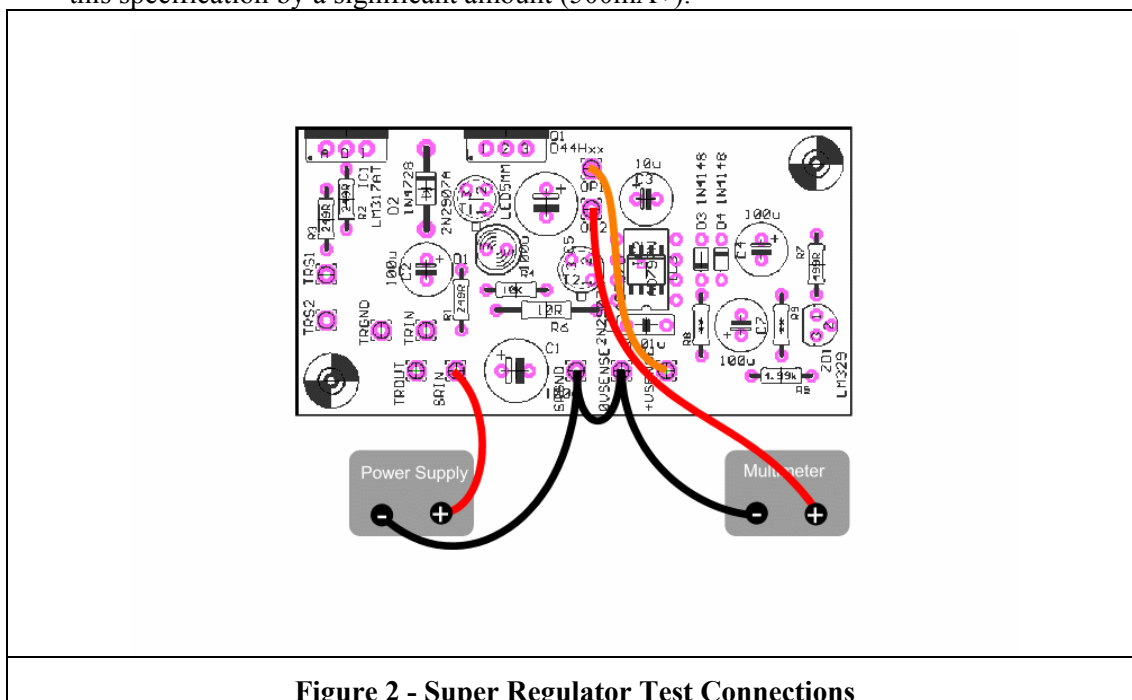

Figure 2 - Super Regulator Test Connections

Commercial in Confidence

9 APPLICATION

The original design goal for the Super Regulator was as a drop-in replacement for the regulator board in a Naim Audio SNAPS power supply. The circuit is relatively compact and very versatile though, and has been implemented into a number of different applications, from internal regulator upgrades in commercial equipment, to external supplies for portable devices, such as MiniDisc players. In every instance the performance gain has been huge.

The following guidance will help you apply the circuit to your individual circumstances and application.

9.1 Choosing configuration

First select the regulator configuration to be used, i.e. with or without tracking pre-regulator. The author strongly recommends use of the pre-regulator in all circumstances where the available raw supply voltage is adequate to ensure correct function. See section 6 - OUTPUT VOLTAGE for guidance.

9.2 Choosing voltage

In most cases one will want to replicate an existing regulator voltage, choose resistor values for R8 / R9 accordingly. If changing voltages for any reason be sure that circuit function will not be affected, and voltage ratings of existing components are adequate.

9.3 Connecting

The diagrams in the Appendices will assist with connecting the Super Regulator to your circuit. Be very careful with connections to the Super Regulator circuit, incorrect wiring can damage components permanently.

9.4 Performance Verification

When applying the regulator to some applications some care has to be observed with the load presented to the regulator, by the circuit being powered. Specifically small film or ceramic capacitors close to the regulator will almost guarantee instability and oscillation. The necessity for such bypass capacitors is reduced by the dramatically low output impedance of the regulator circuit. One can either remove such components, or ensure that they are decoupled by a few inches of PCB track, or small series resistance. Additionally the use of C6 and a series 10R resistor between +VSENSE and OP1 or OP2 will further improve stability margins. It is the very high bandwidth / performance of these regulators that can give rise to such instabilities, it should not be considered a fault of the circuit, but is one of the potential problems of such extreme performance circuits. There are options to further enhance stability for some performance penalty. Please seek advice from the author if such instances are encountered. In all circumstances the large performance advantage over standard regulator circuits is maintained.

Commercial in Confidence

Document Number: ALWSR Rev 2.9	Issue Number: 005	Page 11
-----------------------------------	-------------------	---------

10 MAINTENANCE & REPAIR

The ALWSR Super regulator has been designed to have a long life, with no degradation in performance. Some electronic components do degrade with time though, and it can be beneficial to replace components on old units in order to ensure the very high performance levels are maintained.

In this circuit the above recommendation applies exclusively to the electrolytic capacitors C1 through to C5 + the '0.9' mod capacitor (see section 12). Changing these after approximately 8-10 years use is likely to be beneficial. Some 'running-in' of these devices is likely to be necessary before full sonic benefit is achieved, and this may take several hundred hours depending upon usage.

10.1 Health and Safety

Electricity can kill!

Care should be taken when working on any mains-powered device. Before attempting any work, or opening equipment cases, remove and unplug mains power. Take care and check work thoroughly – the author cannot be held responsible for the end user performing tasks that they are not confident to do.

Seek advice from suitably qualified professionals if you are not confident or experienced enough to perform such work.

Additionally, expensive equipment can be damaged by careless modification. Do not put your precious investments at risk, by attempting work you are not capable of performing to a very high standard.

Commercial in Confidence

Document Number: ALWSR Rev 2.9	Issue Number: 005	Page 12
-----------------------------------	-------------------	---------

11 CALIBRATION

There is no requirement for periodic calibration of this unit, beyond the advice given in the Section **10 - MAINTENANCE & REPAIR**.

The components chosen are of high stability, performance and long life and should only be replaced by similar or better components. Please seek the advice of the author for any modifications one wishes to attempt.

Remember, most of the performance of this circuit comes from the careful choice and selection of the components used.

Commercial in Confidence

Document Number: ALWSR Rev 2.9	Issue Number: 005	Page 13
-----------------------------------	-------------------	---------

21/03/2004

12 The '0.9' BTS[†] modifications.

The constant goal of the author is to improve performance wherever possible, and to offer retrofit upgrades wherever possible. As part of constant R&D the relatively minor modifications detailed in this section are to be made available, having completed field testing, and listening assessments.

These modifications that will now be supplied as standard with future regulators and all can be applied to existing PCB's, the method of doing so depending upon accessibility of the boards and the modifier's abilities.

Three modifications are available, presented in order of musical benefit: -

1. Add an adjustment pin decoupling capacitor to the tracking pre-regulator[‡].

Benefits: Lowers pre-regulator noise and output impedance, improves ripple rejection, brings big sonic gains in terms of Pace, Timing and low-level detail.

This is a 'must-do' modification!

- For retrofit upgrades to existing PCB's a 100-220u capacitor can be added across R3 (249R) on the back of the PCB. See component overlays for orientation. The author can supply suitable high quality capacitors, on request.
- For new build resistors R2 / R3 are changed to 1K, and a 47u Rubycon ZA is supplied to decouple the adjust pin of IC1. The capacitor is fitted from the top-side of the PCB, in place of R3, the resistor is fitted underneath the board.

2. Remove R6, and replace with a wire link, or short R6 out for simpler retro-fit upgrades.

Benefits: Lowers output impedance and both static and dynamic noise, brings improvements to dynamic performance.

3. Change R1 (249R) to 100R.

Benefits: Lowers output impedance and raises current capability, lowering dynamic noise. Brings improvements as per 2 above – **only to be done if using ZTX x51 series transistors.**

- Remove R1 and replace with 100R, or...
- Fit a 180-200R resistor on parallel with R1, on the rear of the PCB.

[†] BTS = **B**etter **T**han **S**ex, nicknamed due to their apparent ability to keep people from their beds until the early hours of the morning, in a music-playing orgy (AUTHOR'S NOTE: DO NOT SAY THIS TO PARTNERS, OR IT MIGHT BE THE ONLY LATE NIGHT GRATIFICATION YOU GET FOR SOME TIME ;))

[‡] Observant readers may wonder why this mod was not standard, as it is considered normal practice to decouple the adjust pin. The reason is that the earlier prototypes, using the AD797 were very hair-trigger with regard to stability, and this capacitor, along with phases of the moon, the colour of my underwear and other exotic influences degraded stability margins...

Commercial in Confidence

Document Number: ALWSR Rev 2.9	Issue Number: 005	Page 14
-----------------------------------	-------------------	---------

13 Annex A – Parts List, Schematics, Component Overlays + Component ID.

Part	Value (+ve version)	Value (-ve version)	Type
C1	100u, 35V	100u, 35V	Rubycon ZA
C2	100u, 10V	100u, 10V	Rubycon ZA
C3	22u	22u	Rubycon ZA
C4	100u, 25V (10V)	100u, 25V (10V)	Rubycon ZA
C5	100u, 35V	100u, 35V	Rubycon ZA
C6	Not Fitted	Not Fitted	See text
C7	100u, 25V (10V)	100u, 25V (10V)	Rubycon ZA
D1	LED5MM	LED5MM	Vishay
D2	1N5342B (1N5333B)	1N5342B (1N5333B)	ON Semi
D3	1N4148	1N4148	Philips
D4	1N4148	1N4148	Philips
IC1	LM317T	LM337T	National Semi
IC3	AD825 (AD817)	AD825 (AD817)	Analog Devices
Q1	D44xHxx	D45xHxx	ON Semi
R1	100R [§]	100R	Beyschlag
R2	1K ^{**}	1K	Beyschlag
R3	1K ^{**}	1K	Beyschlag
R4	10K	10K	Beyschlag
R5	4.99k (249R)	4.99k (249R)	Beyschlag
R6	Wire Link	Wire Link	-
R7	499R	499R	Beyschlag
R8	SOT ^{††} (1K)	SOT (1K)	Beyschlag
R9	SOT ^{††} (1K)	SOT (1K)	Beyschlag
T1	ZTX751	ZTX651	Zetex
T2	ZTX751	ZTX651	Zetex
ZD1	LM329DZ (TL431)	LM329DZ (TL431)	National Semi
PCB	ALWSR+	ALWSR-	ALW Audio
C_Kelvin	47u ^{‡‡}	47u	Rubycon ZA
Sil-Pad			
Insulating bush			
Terminal Pin			
Bracketed values = 5V version			

[§] Value changed from 249R to 100R as part of '0.9' BTS mods

^{**} Value changed from 249R to 1K as part of '0.9' mods

^{††} Select on build for correct voltage

^{‡‡} Added as part of '0.9' mods – value varies depending upon new-build or retrofit upgrade, see section 12 for details



Commercial in Confidence

Document Number: ALWSR Rev 2.9	Issue Number: 005	Page 15
-----------------------------------	-------------------	---------

13.1 Component Identification.

As a result of a continual drive to improve performance whilst keeping costs at sensible levels a number of components have changed during the development of these circuits.

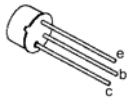
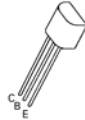
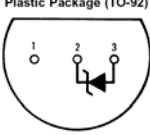
Because of this some improved components are currently supplied that are different in physical appearance from those specified on the component overlays. This section will assist in identification of these components and ensure correct orientation when fitted to the PCB.

Table of Component Changes					
Component reference	Original Component	Revised / Alternative Component	Old Package	Revised Package	Reason for change
T1, T2	2N2907	ZTX751	 TO-18	 E-Line TO92 Compatible	Improved performance, reliability, reduced cost.
D2	1N4728	1N5342B	No change	No change	Expediency – PCB symbol available and used for space model, 1N4728 has never been used.
Q1	D44H8	D44H11	No change	No change	Component availability. The 'H11' variant is of a higher voltage rating, but otherwise identical AC specification.
ZD1 / VR1	LM329	TL431	 Plastic Package (TO-92) Bottom View Order Number LM329BZ, LM329CZ or LM329DZ See NS Package Z03A	 Pin 1. Reference 2. Anode 3. Cathode	TL431 used for 5V regulator only, as LM329 reference voltage too high. See 5V overlay for orientation in board – Pins 1 and 3 MUST be joined on the PCB, bend leg to suit. Additionally a >10uF capacitor can be added between pins 2 and 1+3.

General component identification notes: -

Many components are polarised and must be fitted to the PCB in the correct orientation, the following list will help identify these components.

- Diodes – orientation denoted by band at one end of device.
- LED's – orientation denoted by flat close to one leg of device.
- Transistors – see section 13.1 above.
- Electrolytic Capacitors – polarity denoted by + sign on overlay, + or – sign on component.

Commercial in Confidence

Document Number: ALWSR Rev 2.9	Issue Number: 005	Page 16
-----------------------------------	-------------------	---------

21/03/2004

13.2 ALWSR+ Schematic (not 5V version)

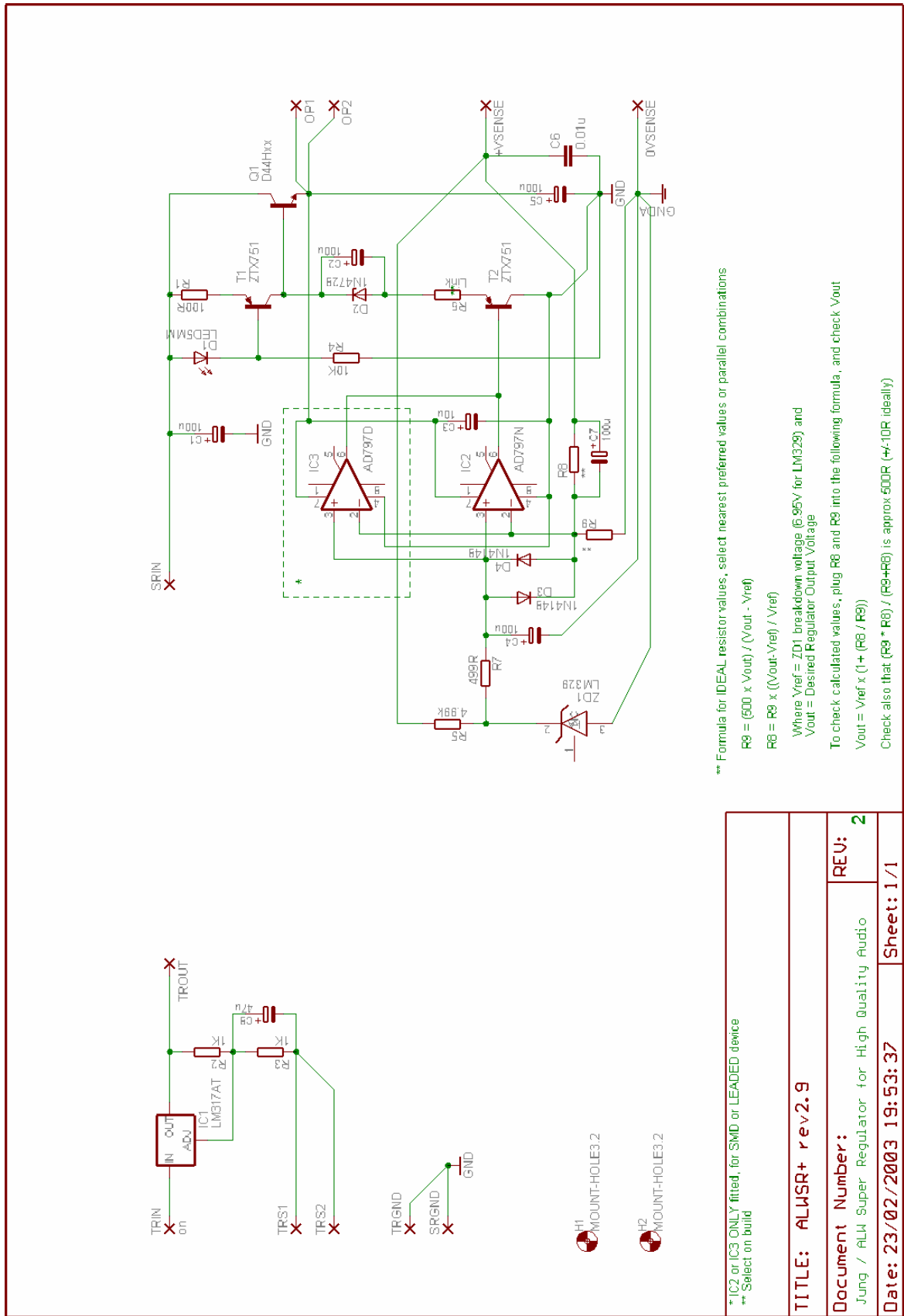

Commercial in Confidence

Document Number: ALWSR Rev 2.9	Issue Number: 005	Page 17
-----------------------------------	-------------------	---------

13.3 ALWSR+ Component Overlay (Not 5V version)

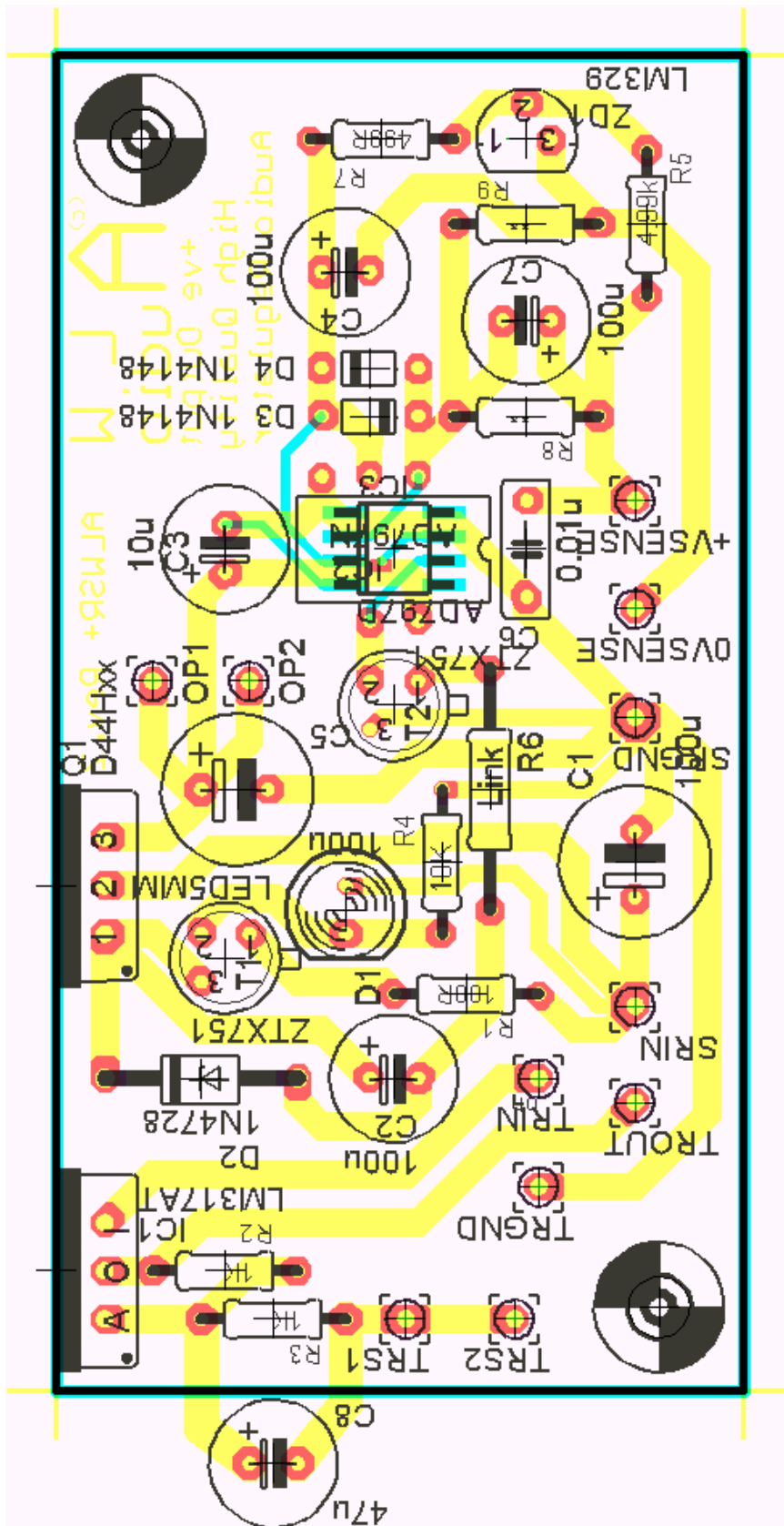

Commercial in Confidence

Document Number: ALWSR Rev 2.9	Issue Number: 005	Page 18
-----------------------------------	-------------------	---------

13.4 ALWSR+ Schematic (5V version)

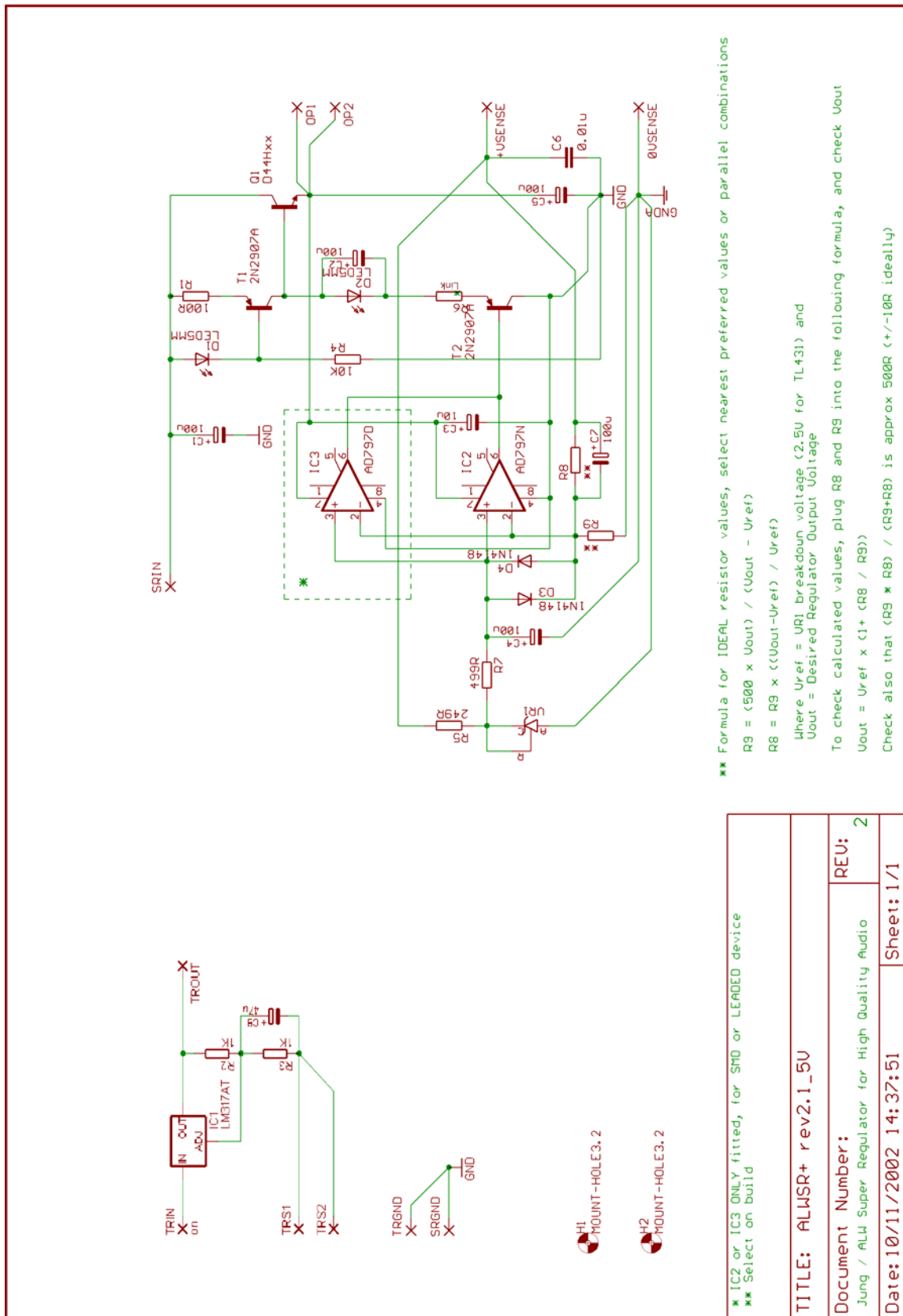

Commercial in Confidence

Document Number: ALWSR Rev 2.9	Issue Number: 005	Page 19
-----------------------------------	-------------------	---------

21/03/2004

13.5 ALWSR+ Component Overlay (5V Version)

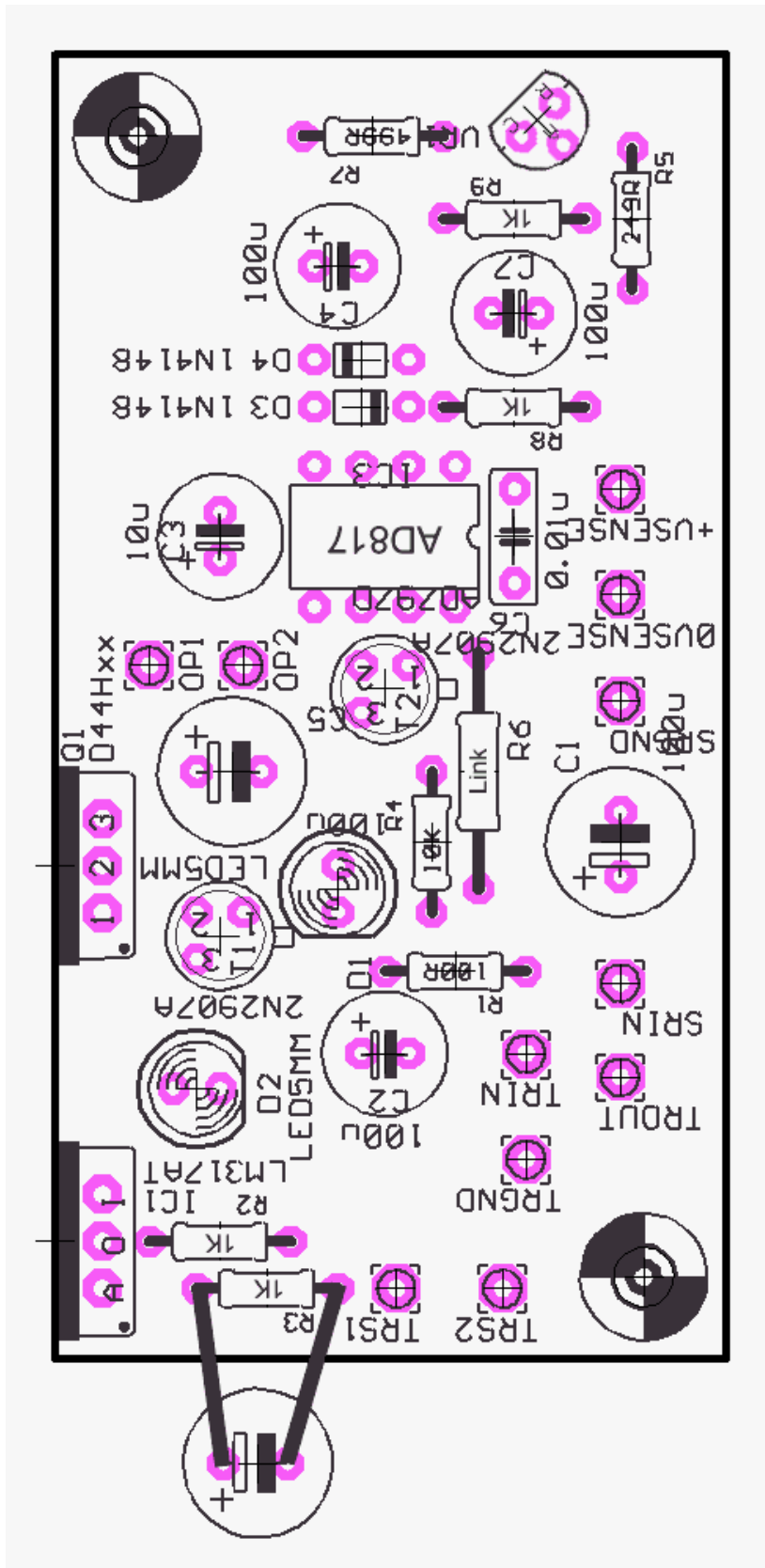

Commercial in Confidence

Document Number: ALWSR Rev 2.9	Issue Number: 005	Page 20
-----------------------------------	-------------------	---------

13.6 ALWSR- Schematic

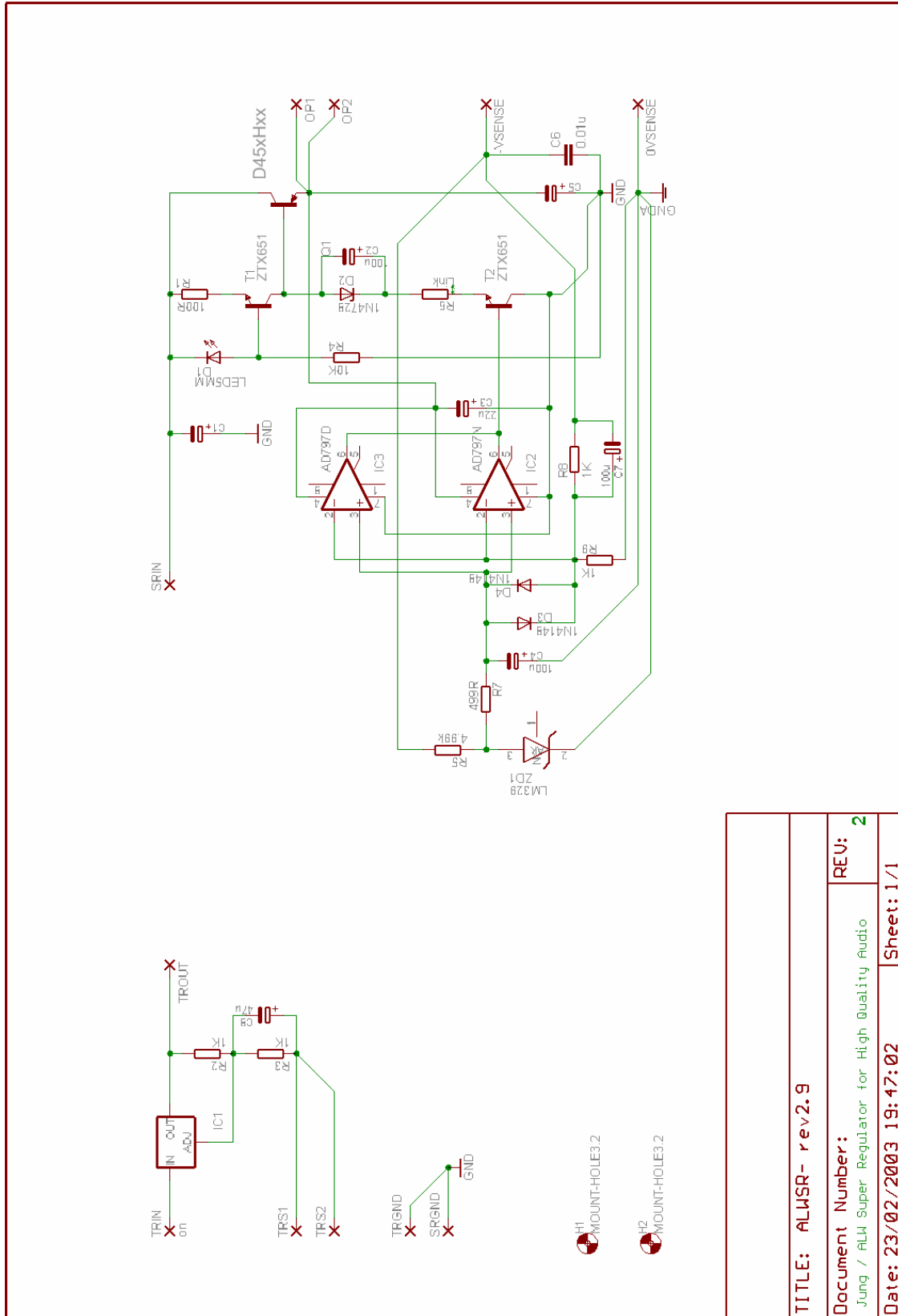

TITLE: ALWSR- rev2.9	
Document Number: Jung / ALW Super Regulator for High Quality Audio	REV: 2
Date: 23/02/2003 19:47:02	Sheet: 1/1

Commercial in Confidence

Document Number: ALWSR Rev 2.9	Issue Number: 005	Page 21
-----------------------------------	-------------------	---------

13.7 ALWSR- Component Overlay

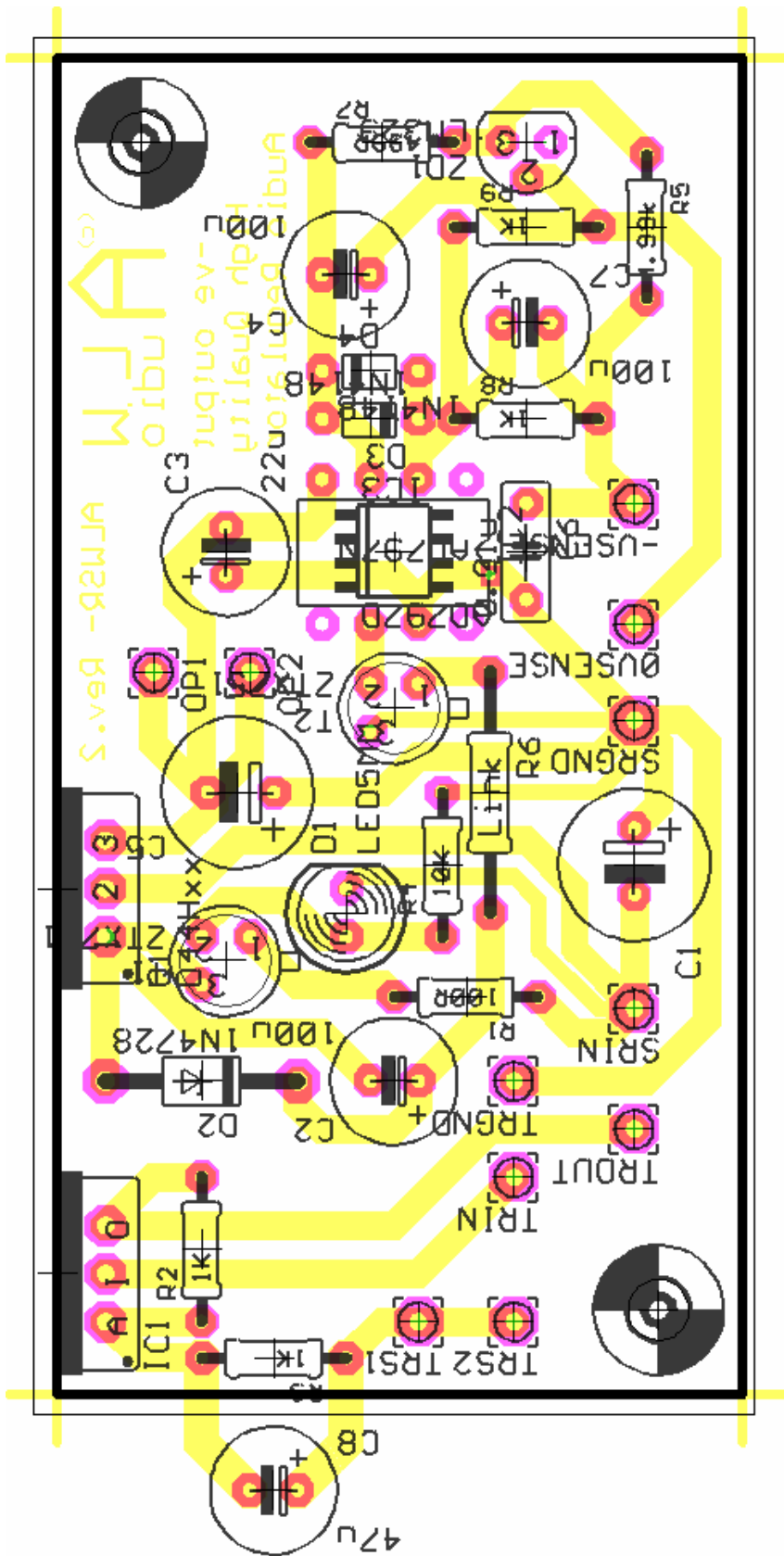

Commercial in Confidence

Document Number: ALWSR Rev 2.9	Issue Number: 005	Page 22
-----------------------------------	-------------------	---------

14 Annex B – Regulator Output Voltage

The following table is intended as a guide to setting output voltage; the values are calculated and represent non-preferred values in most cases. The author suggest choosing the nearest preferred values, then calculating output voltage and divider impedance as detailed in Section 6.

Additionally parallel combinations can be made by fitting two resistors to one or both positions, one from the top of the PCB, one from below.

Output Voltage	R8 Value	R9 Value
8	576	3810
9	647	2195
10	719	1639
11	791	1358
12	863	1188
13	935	1074
14	1007	993
15	1079	932
16	1151	884
17	1223	846
18	1295	814
19	1367	788
20	1439	766
21	1511	747
22	1583	731
23	1655	717
24	1727	704
25	1799	693
26	1871	682
27	1942	673
28	2014	665
29	2086	658
30	2158	651
31	2230	644
32	2302	639
33	2374	633
34	2446	628

Commercial in Confidence

Document Number: ALWSR Rev 2.9	Issue Number: 005	Page 23
-----------------------------------	-------------------	---------

15 Annex C – Wiring / Connection Schemes.

The large performance benefits of these regulators can be totally ruined through careless implementation and poor wiring, so the following diagrams are provided in order to give examples of good and bad wiring, along with various connections schemes, which can be chosen depending upon a particular application.

The one clear thing to remember (true for ALL voltage regulators), is that the best performance is obtained ONLY at the point at which the 0VSENSE and +VSENSE connections are made. The following diagram shows two wiring schemes, one optimal, one very poor.

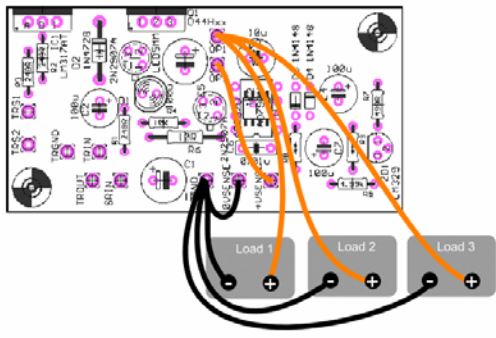
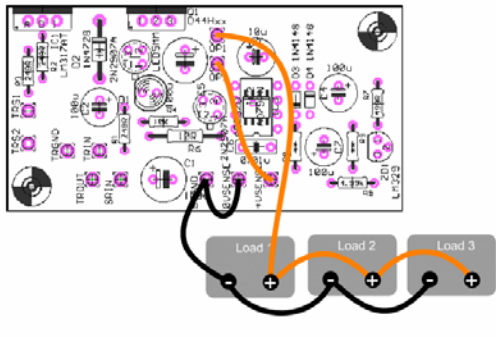
	<p>Figure 3 - Optimal Star Wiring</p> <p>This star wired scheme gives optimal performance in any given situation. Load 1, 2 and 3 represent circuits being powered by the regulator. In this scheme the regulator is sensing (i.e. measuring) the output voltage between OP1/2 and 0V. Any errors introduced as a result of the load currents changing are corrected by the regulator circuit such that the loads do not interfere with one another.</p>
	<p>Figure 4 – Bad Wiring</p> <p>This wiring scheme will negate many of the benefits of using these regulators. Again the regulator is sensing the output voltage between OP1/2 and 0V. Load 1 sees the best PSU, although the current flows to Load 2 and 3 will degrade it, Load 2 and 3 see very poor PSU performance, since the load current drawn by each causes a voltage drop along the wiring. This may seem trivial, but since noise has been reduced to sub-microvolt levels, the finite resistance of the wiring will cause significant voltage fluctuations that vary with the dynamic behaviour of the load.</p>

Various connection schemes follow, which can be implemented into a variety of applications.

Commercial in Confidence

Document Number: ALWSR Rev 2.9	Issue Number: 005	Page 24
-----------------------------------	-------------------	---------

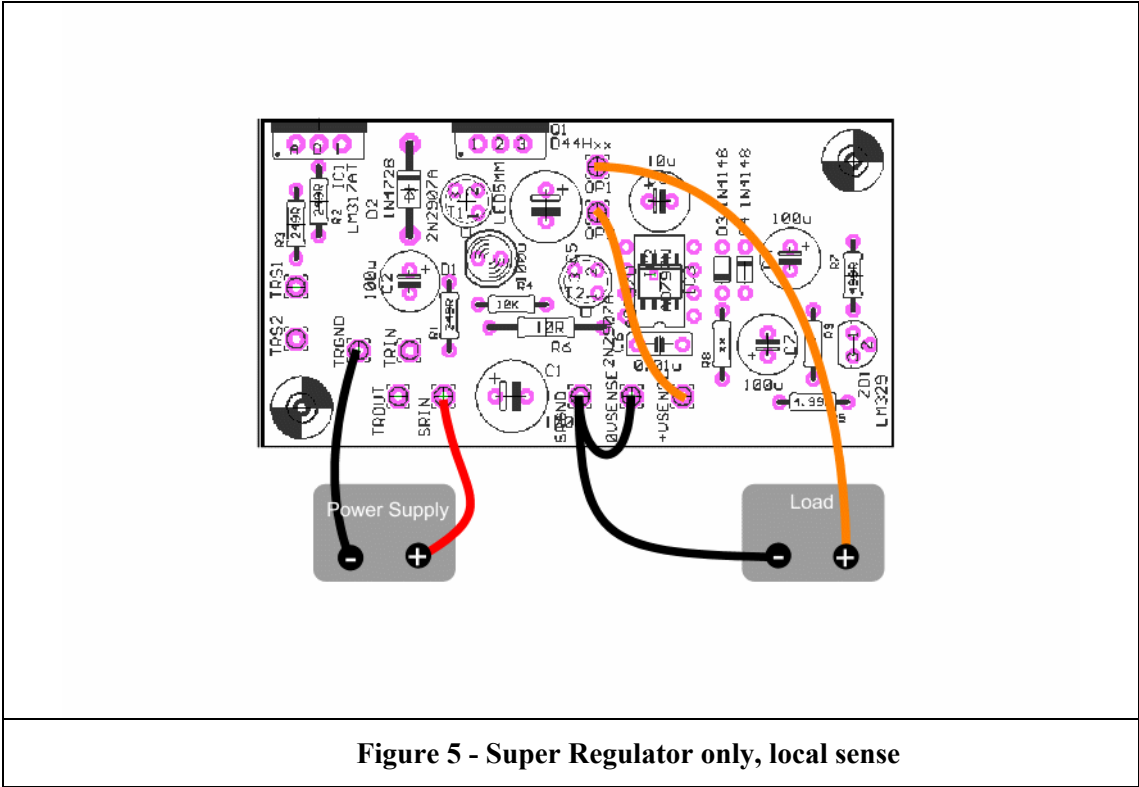

Figure 5 - Super Regulator only, local sense

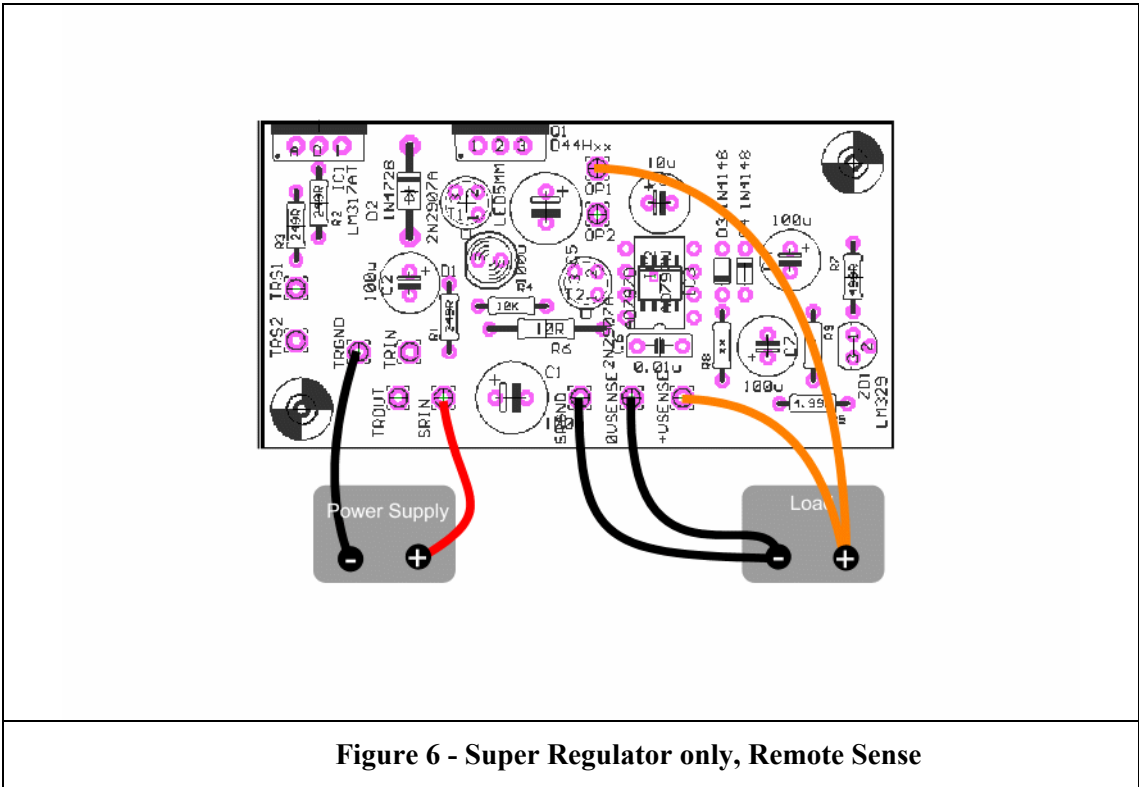

Figure 6 - Super Regulator only, Remote Sense

Commercial in Confidence

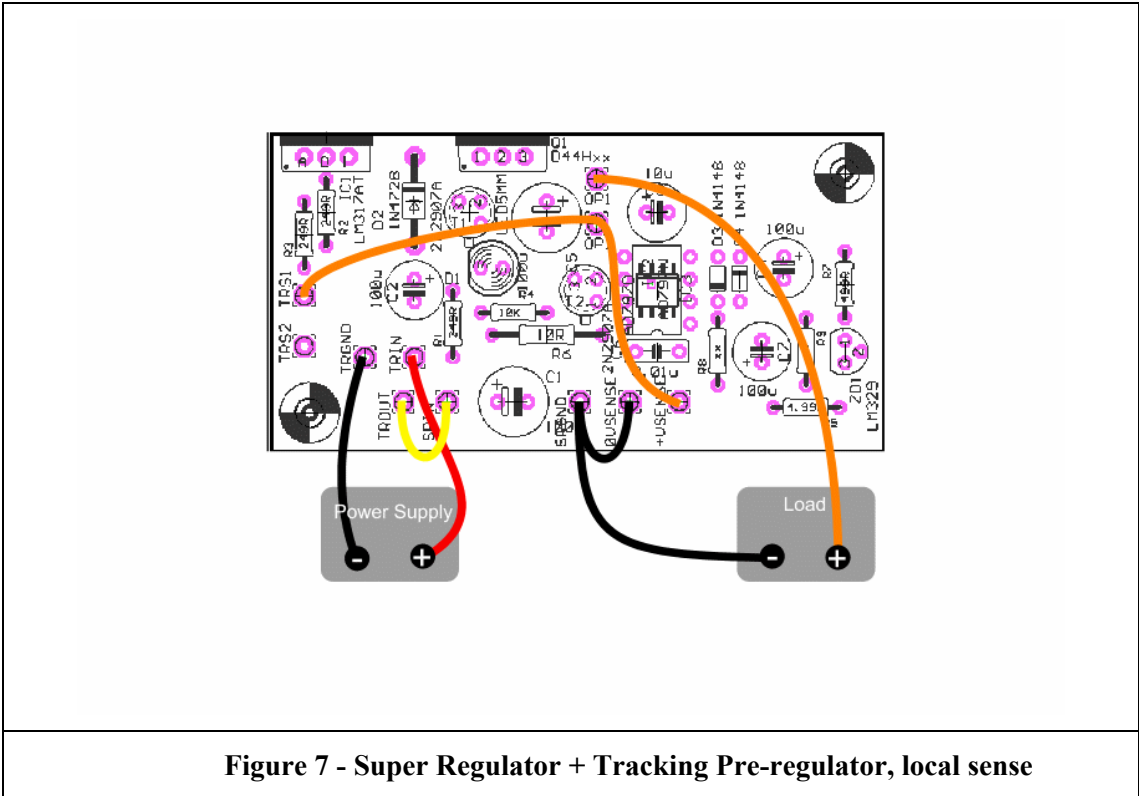

Figure 7 - Super Regulator + Tracking Pre-regulator, local sense

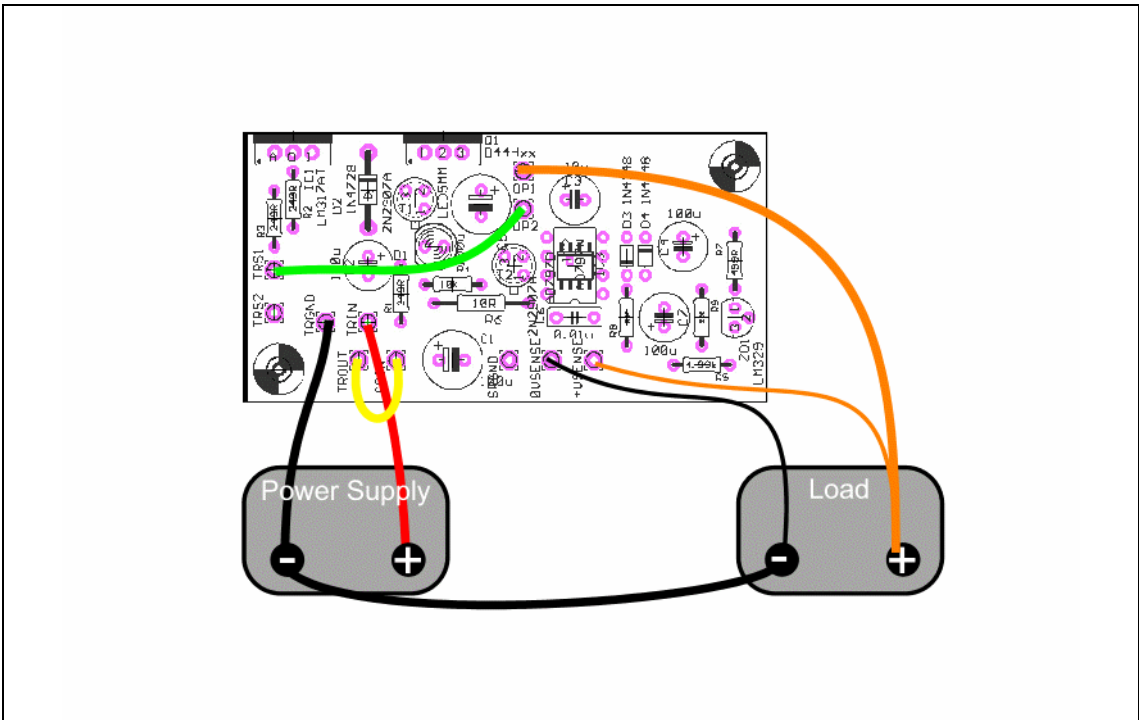

Figure 8 - Super Regulator + Tracking Pre-regulator, remote sense

This connection scheme is recommended for the Naim SNAPS power supply, where the sense connections are made at the 5pin DIN socket. All of the 0V returns for the 4pin sockets must also be made to the 5 pin DIN socket 0VSENSE point. With care and suitable choice of

Commercial in Confidence

wiring this can be done easily, see SNAPS Fitting document for more details.

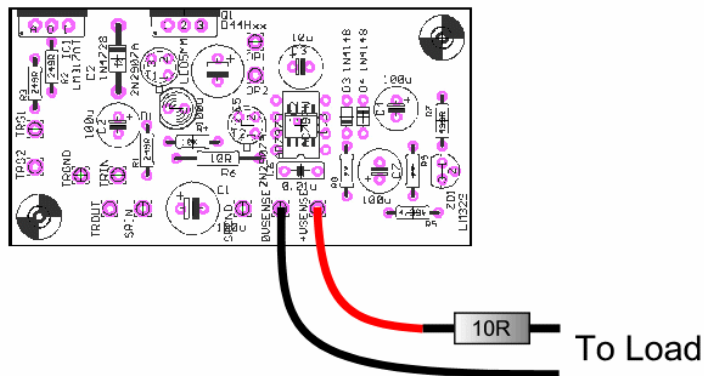

Figure 9 - Sense loop filter^{§§}

This is to be used in conjunction with C6 on the PCB which must ONLY be fitted if the 10R resistor is added to the sense line. It is possible, when using remote sensing, for oscillation to occur.

If oscillation is experienced an examination of the decoupling of the circuit being powered is the first choice – any small value film or ceramic capacitors, or large value capacitors (>100u) should be either examined for necessity or decoupled from the regulator output (via a length of PCB trace / wiring etc.).

Also consider routing of sense wiring to see if pick up as it passes noisy circuit is the problem.

If this fails to produce the desired results, or the above options are not practical then the addition of the network C6 (0.01u) and a 10R resistor in the +VSENSE line AT THE LOAD may help.

Do not connect the resistor at the regulator +VSENSE pin, it is less effective and does not decouple the sense wiring's capacitance from the regulator output (another source of oscillation when remote sensing is implemented).

The author has not had a single example that by the methods above could not be made to produce overall stability under all operating conditions - please contact me if difficulties are experienced.

^{§§} Note: the AD825 based units have never experienced oscillation in any of the applications the author has tried them in. This information is presented primarily for historical interest, and to provide a method, in the unlikely event of problems, to solve difficult applications.

Commercial in Confidence